



Spring | 2012

E Ink Segmented Displays

Prototype Display Design Rules Version 2.0

Table of Contents

1.0 E Ink Background	3
1.1 How Does E Ink Work	3
1.2 E Ink Segmented Display Construction	3
2.0 How the Art-to-Display Development Process Works	4
3.0 Design Considerations	4
4.0 Graphic Design Rules.....	5
4.1 Minimum Feature Pad	5
4.2 Minimum Feature Width	5
4.3 Minimum Feature Gap.....	6
4.4 Routing Considerations	6
4.5 Image Overlap.....	7
5.0 Mechanical Design Rules.....	7
5.1 Maximum Active Area / Minimum Active Area	7
5.2 Display Thickness.....	7
5.3 Edge Seal.....	8
5.4 Maximum Display Size / Minimum Display Size	8
5.5 Vcommon Location.....	8
5.6 Minimum Tail Size	8
5.7 Connector Pitch	10
6.0 Segment Mapping	9
7.0 Overall Design Rules Based on Display Type	10
8.0 What the customer needs to provide E Ink	10

1.0 E Ink Background

E Ink Corporation is the creator of electronic ink — the optical component of a proprietary film used in Electronic Paper Displays. Although futuristic in concept, electronic ink is a straightforward fusion of existing knowledge in chemistry, physics and electronics. E Ink displays offer high contrast, superior paper-like readability and low power consumption, drawing power only when switching the display.

1.1 How Does E Ink Work?

Electronic ink is made up of millions of tiny microcapsules, about the diameter of a human hair. Each microcapsule contains positively charged white particles and negatively charged black particles which are suspended in a clear fluid. When a positive or negative electric field is applied, corresponding particles move to the top of the microcapsule where they become visible to the user. This makes the surface appear white or black at that spot.

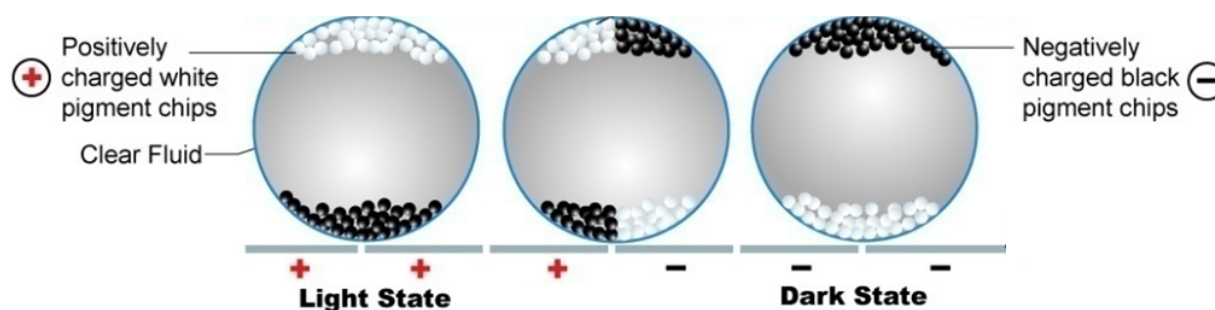

1.2 Segmented Display Construction

E Ink Segmented displays are comprised of four layers. The ink is coated onto a sheet of plastic film that is then laminated to a back plane with electrical connections. The back plane is manufactured using either printed carbon (PET) or Polyimide. When manufacturing a Segmented display, the film and back plane are then sealed between top and rear environmental protective layers, ensuring the internal conditions of the display are maintained and optimized for switching the ink.

The figure below shows a cross-section view of an E Ink Segmented display including from top to bottom: Top protective layer, E Ink film, back plane connection, and rear protective layer.

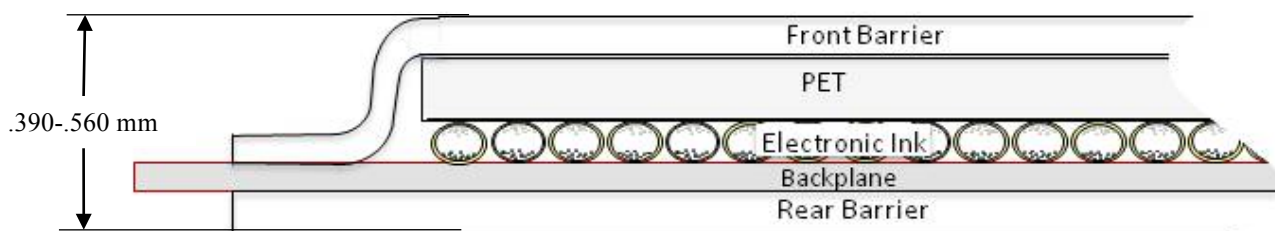

Each segment on an E Ink display has an individual electrode on the back plane. Each electrode is routed on the back plane, forming a display connector or tail off the edge of the display. For a Segmented Display Cell (SDC), the tail includes one trace for each segment plus two additional traces for top plane and back plane connection. For example, if your display uses 96 segments, the tail would include 98 traces or pin outs.

2.0 How the Art-to-Display Development Process Works

The customer is responsible for providing art and other requirements for the display, in the format prescribed by E Ink. E Ink will designate an application engineer who will answer the customer's questions and ensure that the customer's art and requirements can be met. Using the customer's art and requirements, E Ink will create prototype Segmented Displays based upon the customers' needs.



3.0 Design Considerations

E Ink displays support unique features not found in your typical LCD display design:

Any 2D Shape: E Ink Segmented displays can be manufactured in any 2D shape such a circle, triangle, or abstract shape, enhancing industrial designs.

Smooth Curves: Curves will look crisp and smooth because they are based on the vector artwork. The smooth curves found in the underlying design will translate directly onto the final E Ink display, unlike the “stair-step” effect you sometimes see with traditional LCD.

Merging Segments: E Ink segmented displays have the capability under certain constructions to create seamless letters, without the inter-character gaps found in traditional display technologies. When adjacent elements are activated together, the elements will merge and the line between them will not be visible.

4.0 Graphic Design Rules

Follow these graphic design rules to create artwork suitable for E Ink Segmented Displays. Backplane options for E Ink Segmented Displays are either PET (200um), or Polyimide (100um), which is typically the better option for highly detailed designs with limited space.

4.1 Minimum Feature Pad

Each enclosed element of the design must be large enough to contain a pad of 0.450mm or 0.500mm in diameter in order to support the electrical connection. If the area is smaller 0.450mm, then it would no longer possible to activate that portion of the display. This is shown below.

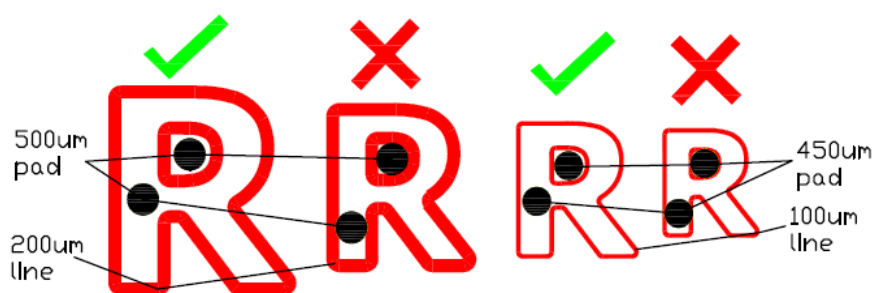

4.2 Minimum Feature Width

Minimum width is defined as the smallest area of a feature while maintaining an electrical connection. Once an element has an area large enough to fit the minimum feature size, then it can narrow down to a smallest width of 0.100mm. This is shown below.

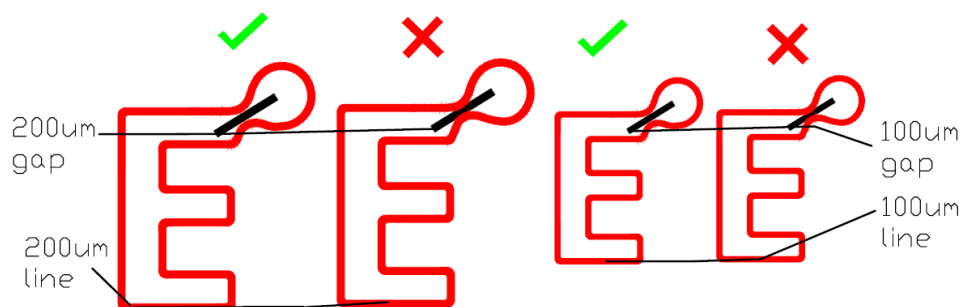

4.3 Minimum Feature Gap

Minimum Gap is defined as the smallest separation of a feature while maintaining isolation from another electrical connection. The minimum gap can be as low as 0.100mm.



4.4 Routing Considerations

Once the areas of sections 4.1 - 4.3 are satisfied you need to ensure electrical connections can be made reliably. Each connection will go to the feature pad and must maintain separation from other features while maintaining a minimum gap of 0.100mm. Each electrical trace must be able to be routed to the connector on the outside edge of the display.

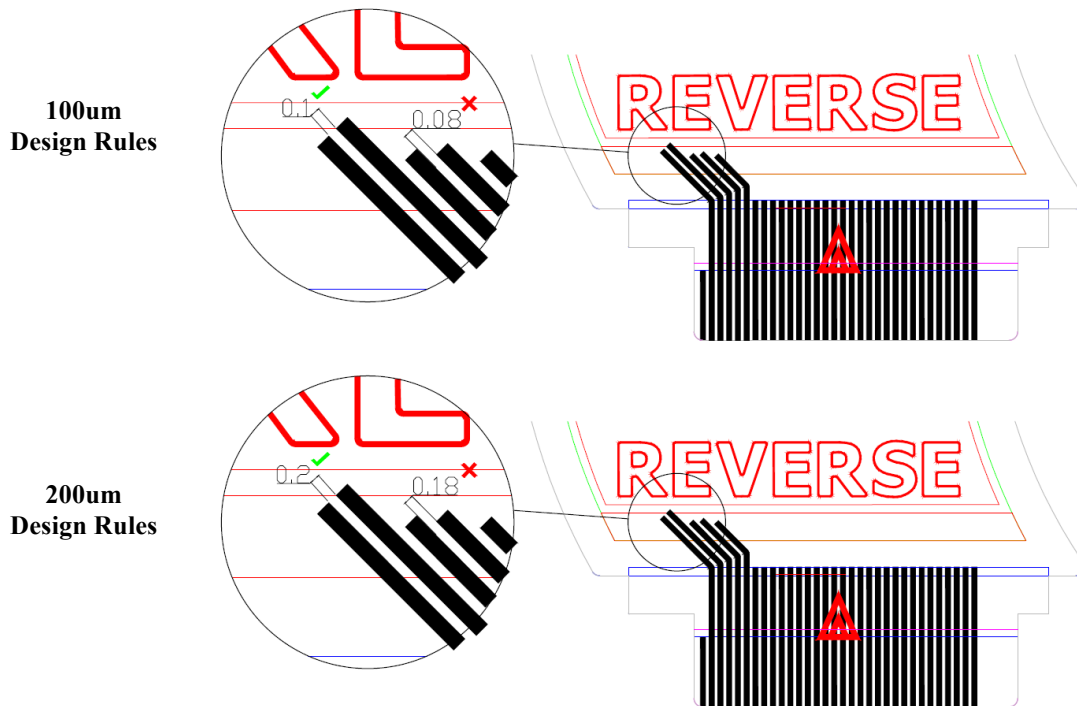

4.5 Image overlap

Overlap is produced when two or more features need to occupy the same area but display multiple images. Overlapping images create small segments, and each of these segments must satisfy the design criteria of stroke thickness, connection pads, and minimum width. When you overlap 2 characters you not only have the original characters you now have features which are now part of both original characters.



5.0 Mechanical Design Rules

Follow these dimension design rules to create artwork suitable for E Ink Segmented Displays.

5.1 Maximum Active Area / Minimum Active Area

The maximum active area for E Ink Segmented displays 220mm x 360mm. Minimum active area is based on shape and size of active area.

5.2 Display Thickness

The thickness of a segmented display ranges from 360-540 microns. The thickness used is dependent on the customers design needs.

5.3 Edge Seal

The minimum edge seal required for an E Ink Segmented display is 2mm.

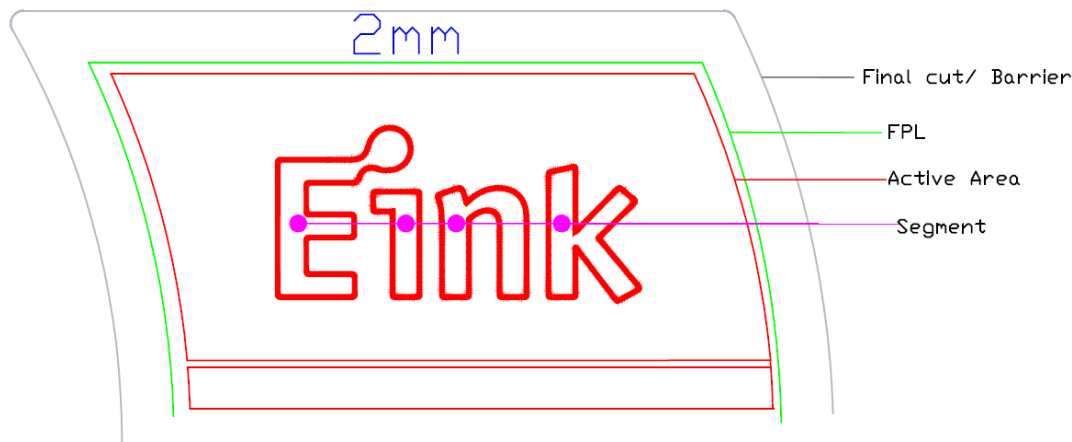

5.4 Maximum Display Size / Minimum Display Size

The maximum display size for an E Ink Segmented display is 224mm x 364mm. Minimum display size is 6mm x 6mm.

5.5 Vcommon Location

There must be a location outside of the Active Area for the electrical Vcommon connection. The size of this area can vary according to the final part size. The minimum V Common size is 1.5mm x 2.0mm and must be located .5mm from the Active Area of the display. In addition, larger displays may want to use two Vcommon locations for redundancy and reliability.

5.6 Minimum Tail Size

The minimum tail size for an E Ink Segmented display must be at least 4.0mm to allow for suitable connection.

5.7 Connector Pitch

E Ink can support a minimum 0.4mm pitch (center to center) for drivelines. It is important to count the total number of drivelines and allocate adequate space for the required number of connections.

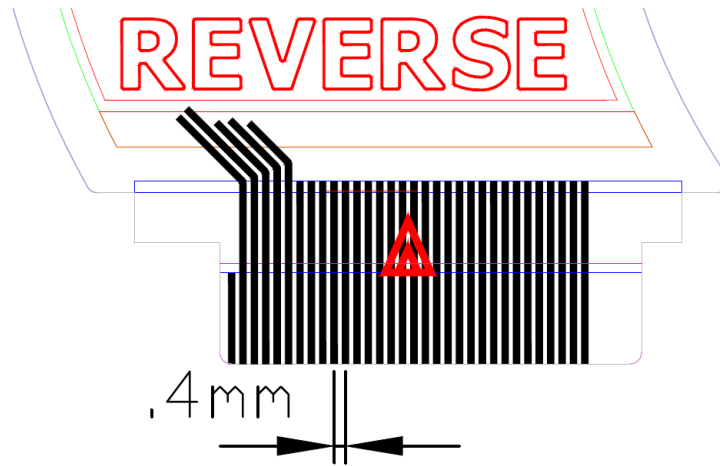

6.0 Segment Mapping

Segments that always activate together can be connected to the same drive line. The Segment Mapping Document should indicate such grouping, so it also specifies the total number of required drive lines.

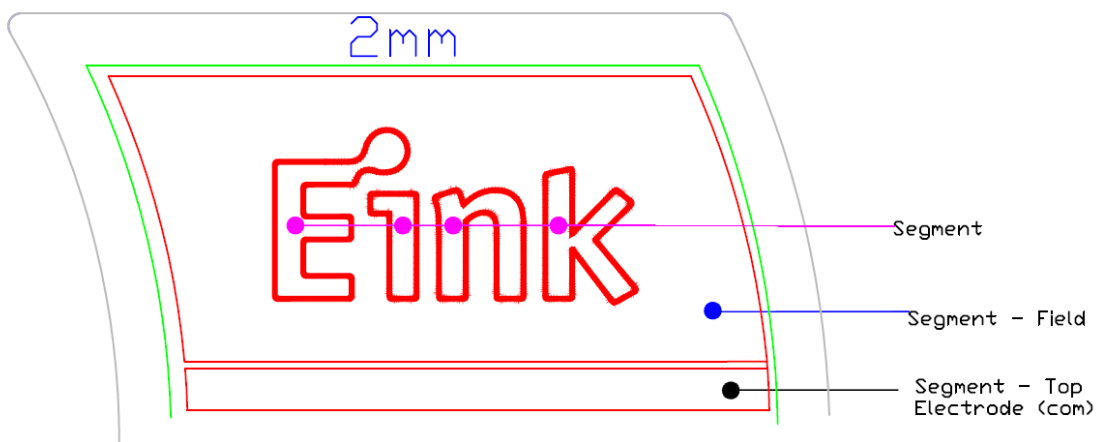

7.0 Overall Design Rules Based on Display Type

Please refer to the chart below for minimum design rules based on display type and back plane.

	SDC		SDM
Definition	Segmented Display Cell		Segmented Display Module with fully integrated driver IC
Back Plane Material	PET	PI	PI
Min. Feature Pad	500 micron	450 micron	35 micron
Min. Feature Width	200 micron	100 micron	60-80 micron
Min. Feature Gap	200 micron	100 micron	60-80 micron
Minimum Tail Size	4.0mm	4.0mm	4.0mm
Drive Line Spacing	40 micron	40 micron	30 micron
Cost	\$	\$\$	\$\$\$

**SDM includes integrated E Ink Driver*

8.0 What the customer needs to provide E Ink

The customer needs to provide the following artwork:

- CAD file of the display pattern. EInk can support Adobe Illustrator (.ai) and AutoCAD LT (.dxf or .dwg) files. This file must conform to the rules described in section 4.1. Design should contain all available dimensional information and noted scale if not 1:1.
- Conceptual drawing of how the display will be incorporated if available.
- Definition of the segment mapping. This file should show the logical grouping of the display pattern into the “segment groups.” See section 4.3 for more information.

Note: Proper file format and display cell dimensions must be present to move forward with any design. Preferences for the driveline location, pitch, or preferred pixel mapping are only needed if there is a desired configuration for these attributes.